

ANDLY

Product Catalogue

Lined Ball Valve BLL1 Series



ANDLY 株式会社
ANDLY Co., Ltd.

BLL1 Series Lined Ball Valve

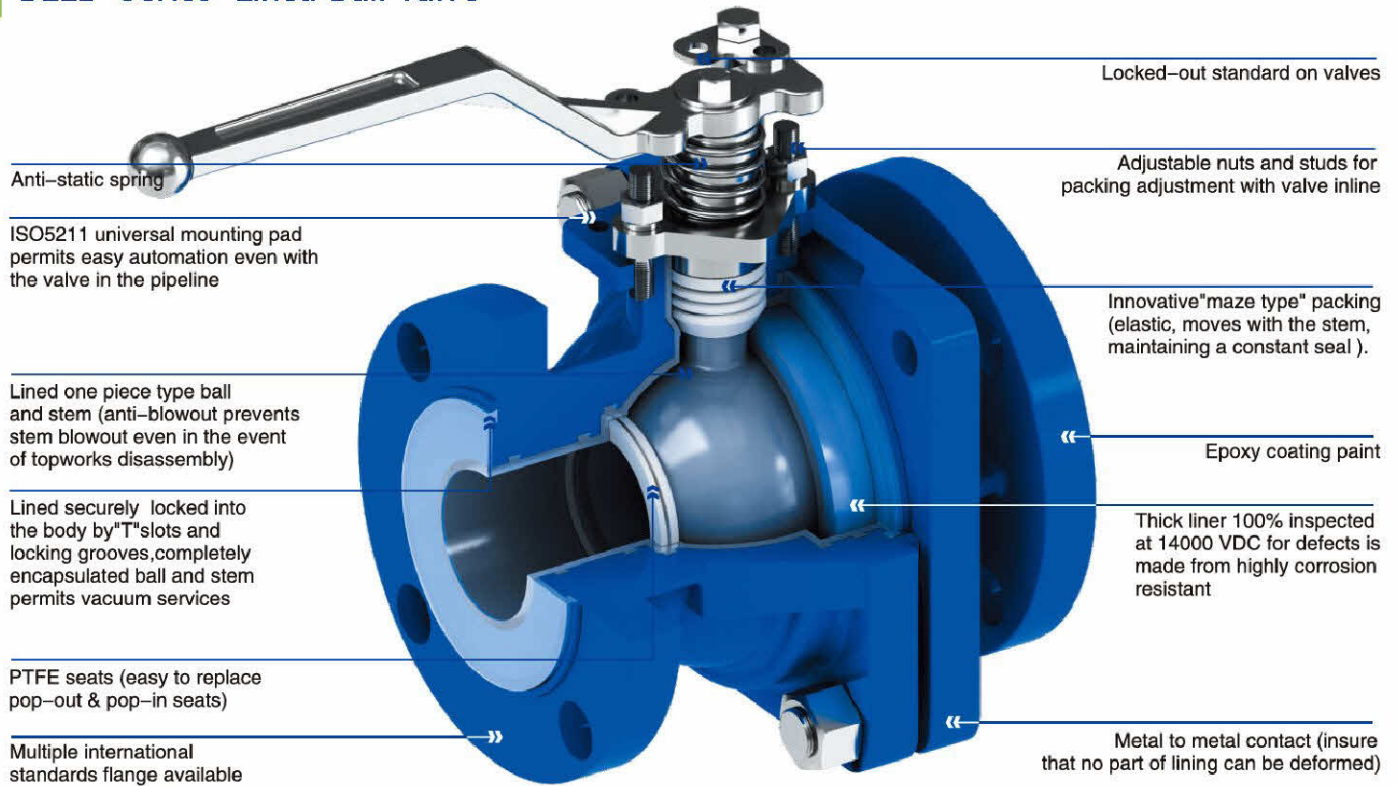

Size	15mm~300mm (0.5"~12")
Working pressure	0.1mbar~16 bar
Temperature range	-20° C ~ 200° C according to working conditions, other temperatures on request.
Design and Manufacture	API 608 DIN 3357 JIS B2071
Face to Face	ASME B16.10 DIN 3202 JIS B2002
Flange Ends	ASME B16.5 DIN 2532 JIS B2212
Visual Inspection	MSS Sp54
Testing	API 598 DIN 12569 JIS B2003
Pressure & Temperature	ASME B16.34
Operator Type	Lever/ Gear/ Pneumatic/ Electric
Spark testing	14kv

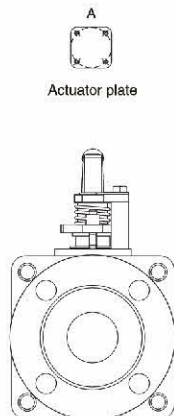
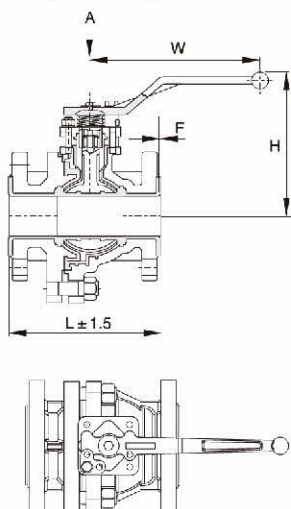
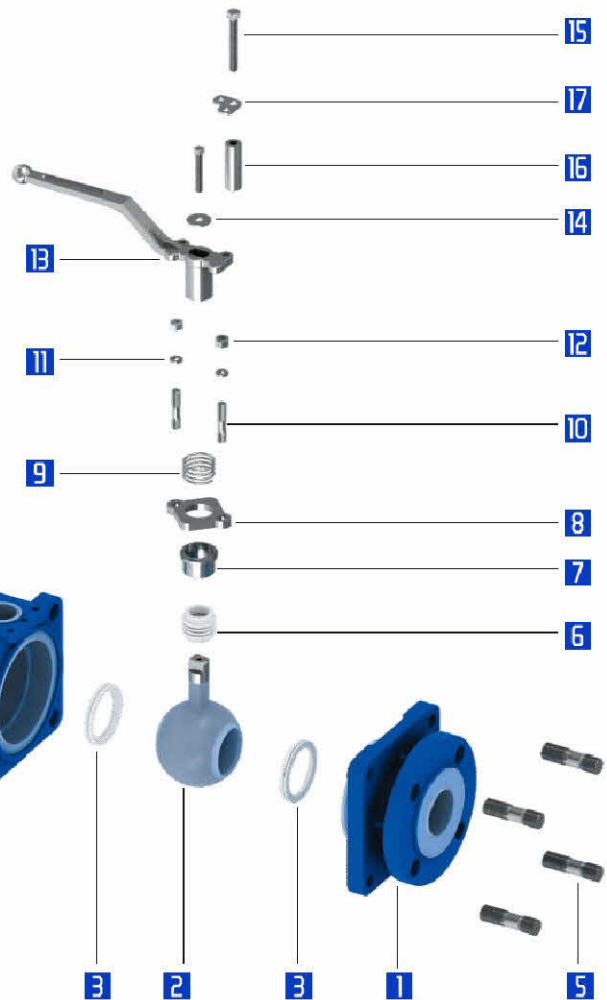

BLL1 Series MATERIALS SELECTION

No	Description	Qty.	Materials	Materials According to Norms		
				ASME	JIS	DIN
1	Body	2	Carbon Steel+PFA/FEP/ETFE	A216 WCB	G5151-SCPH2	GS-45(1.0446)
			Stainless Steel+PFA/FEP/ETFE	A351 CF8	G5121 SCS13A	G-X6CrNiMo1810
			Ductile Iron+PFA/FEP/ETFE	ASTM A395	FCD40	GGG-40 (0.7040)
2	ONE-PIECE BALL	1	Carbon Steel+PFA/FEP/ETFE	A216 WCB	G5151-SCPH2	GS-45(1.0446)
			Stainless Steel+PFA/FEP/ETFE	A351 CF8	G5121 SCS13A	G-X6CrNiMo1810
			Ductile Iron+PFA/FEP/ETFE	ASTM A395	FCD40	GGG-40 (0.7040)
3	SEAT RING	2	PTFE	-	-	-
4	STUD BOLT	4	Stainless Steel	A 182 F304	G4303-SUSF304	X5CrNi18 10 DIN 1.4301
5	NUT	4	Stainless Steel	A 182 F304	G4303-SUSF304	X5CrNi18 10 DIN 1.4301
6	PACKING MATERIAL	1	PTFE	-	-	-
7	SHAFT SLEEVE	1	Stainless Steel	A 182 F304	G4303-SUSF304	X5CrNi18 10 DIN 1.4301
8	GLAND	1	Stainless Steel	A 182 F304	G4303-SUSF304	X5CrNi18 10 DIN 1.4301
9	ANTI-STATIC SPRING	1	Stainless Steel	A 182 F304	G4303-SUSF304	X5CrNi18 10 DIN 1.4301
10	STUD BOLT	2	Stainless Steel	A 182 F304	G4303-SUSF304	X5CrNi18 10 DIN 1.4301
11	WASHER	2	Stainless Steel	A 182 F304	G4303-SUSF304	X5CrNi18 10 DIN 1.4301
12	NUT	2	Stainless Steel	A 182 F304	G4303-SUSF304	X5CrNi18 10 DIN 1.4301
13	HANDLE	1	Stainless Steel	A 182 F304	G4303-SUSF304	X5CrNi18 10 DIN 1.4301
14	WASHER	2	Stainless Steel	A 182 F304	G4303-SUSF304	X5CrNi18 10 DIN 1.4301
15	BOLT	2	Stainless Steel	A 182 F304	G4303-SUSF304	X5CrNi18 10 DIN 1.4301
16	LEVER STOP	1	Stainless Steel	A 182 F304	G4303-SUSF304	X5CrNi18 10 DIN 1.4301
17	LOCKER	1	Stainless Steel	A 182 F304	G4303-SUSF304	X5CrNi18 10 DIN 1.4301

BLL1 Series DIMENSION

(Unit:mm)

DN	NPS	ASME 150LB			JIS 10K			DIN Pn10			A	Weight	CV	Torque
		L	H	W	L	H	W	L	H	W				
mm	in										ISO 5211	[kg]		[N · m]
15	½	108	126	160	130	126	160	130	126	160	F05	3.5	20	9
20	¾	117	126	160	150	126	160	150	126	160	F05	4.6	20	9
25	1	127	131	160	160	131	160	160	131	160	F05	5	55	9
32	1¼	140	131	160	180	131	160	180	131	160	F05	5.5	55	20
40	1½	165	160	200	200	160	200	200	160	200	F07	11	210	20
50	2	178	170	200	230	170	200	230	170	200	F07	14	310	26
65	2½	190	170	200	290	170	200	290	170	200	F07	19	310	26
80	3	203	230	260	310	230	260	310	230	260	F07	28.8	684	65
100	4	229	265	313	350	265	313	350	265	313	F10	44.8	1456	91
125	5	/	265	313	400	265	313	400	265	313	F10	51	1546	91
150	6	267	347	535	480	347	535	480	347	535	F12	96.2	3262	143
200	8	292			600			600			F14	118	4565	364
250	10	533	Gear Box		730	Gear Box		730	Gear Box		F14	330	10250	455
300	12	610			850			850			F16	460	17500	494

承同創興

ANDLY

ANDLY Co., Ltd.

4-3-37,TATSUMI-HIGASHI,IKUNO-KU,
OSAKA-CITY,OSAKA,544-0014 JAPAN

URL: www.andly.jp

TEL: +81-06-7509-4724

